

# CLEARED FOR TAKEOFF

## Aerospace Solutions



**SHOP THESE  
SOLUTIONS**





# Reach New Heights Using Kennametal's Aerospace Solutions

The aerospace industry is vast and complex with new regulations taking off every day—but you can count on our legacy in the design and development of aerospace tooling solutions to take your projects to new heights. We have aerospace expertise, solution-driven products and unmatched, expert technical support you can rely on to navigate the challenges of aerospace machining like tough materials, intricate designs and tight tolerances.

We are in tune with this industry's developing landscape and often fluctuating demand for parts, with some of our tooling solutions even touted by major industry players as go-to's for excellence and optimized production in your aerospace operations.



**Ready for takeoff?**  
[kennametal.com/aerospace](https://www.kennametal.com/aerospace)

# WHY YOU CAN COUNT ON KENNAMETAL

## **Aerospace Expertise**

We are your go-to from the field to the lab, whether for the implementation of complex tool paths or development of tooling solutions for your unique aerospace components. We're pioneers in working with high-temp alloys and masters in recommending machining methods that can bring your visions to life with increased performance and precision.

## **Solution-Driven Products**

Our full offering of aerospace-specific tooling, accessories and tooling systems is designed to meet the unique needs of the aerospace market, like working efficiently on high-temp alloys, composite materials, aluminums and hard alloys. From our coating technologies to our material-specific tooling designs, we have aerodynamic solutions that can optimize performance and we continue to push the envelope on new technologies every day.

## **Machining Strategy and Programming Support**

Whether you are working on something entirely new or reprogramming an existing part, we have the technical know-how to help you improve process and productivity. Our team utilizes the latest in digital tools and CAM packages to simulate and recommend the right machining strategy for your unique needs.

## **Building Better with Dynamic Partnerships**

Manufacturers choose to partner with us because of our established relationships, built over decades, with key customers, machine tool builders, suppliers and original equipment manufacturers who work with us to support this rapidly and continually developing industry.

## **Unmatched, Global Application Support**

Whether you're handing us a blueprint for a custom component design or seeking a material-specific tooling solution, our team has the in-depth application, materials science and process engineering know-how to make it happen. We can help you capitalize on existing assets and deliver solutions that increase your productivity. Our dedicated team of specialists is focused on your needs from start to finish.

# ENGINE CASES & DISKS

## TURBINE DISKS

These complex titanium or Ni-based alloy parts require management of low thermal conductivity and vibration to avoid part deformation. There is an increased need for application specific tooling to provide required cooling capabilities.

## CASES

These larger components require challenging process controls and careful application with tool pressure in mind. Materials include aluminum, titanium and Ni-based alloys where internal and external milling operations must consider thin-wall features and fine surface finish requirements.

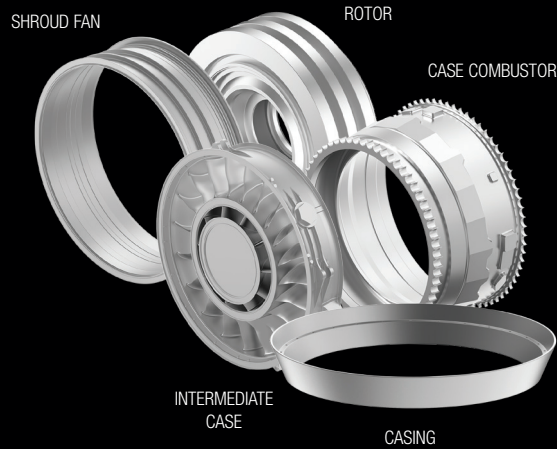

COMPONENTS SOLUTIONS



### KCS10B Grade

- Delivers longer tool life with high depth-of-cut notching resistance
- Optimum layer adhesion for increased process reliability and sharp cutting edges

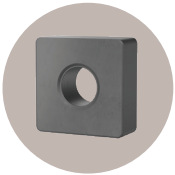

### KYS25 Grade

- Excellent surface finish, lower cutting forces and higher speeds
- Advanced CVD coating provides excellent chemical and depth-of-cut notch resistance

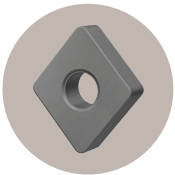

### KYS30 Grade

- Long, consistent tool life
- Excellent toughness and depth-of-cut notch resistance
- Performs in a wide variety of machining conditions, including interrupted cuts and applications involving scale



### A4™ Grooving & Turning Inserts

- Extra-long clamping area, ground 120° bottom prism seating surface and an exclusive top guide rail combine to deliver unsurpassed grooving and side-turning stability
- Precise insert positioning is ensured for accurate cuts
- Rigid clamping securely locks insert in place through the toughest cuts
- Chip control inserts provide excellent chip evacuation in grooving and offer better chip control in multi-directional turning



### Beyond Evolution™ Grooving & Cut-Off

- Single-side grooving, cut-off and multi-directional turning
- Triple-V insert seating for high stability and precise insert positioning
- Fan effect precisely delivers coolant to cutting zone and improves chip control and tool life

### GOdrill™ Solid Carbide Drills (see pg. 5)

# ENGINE BLISKS & BLADES

## BLISKS

Blisks are difficult to machine due to toughness and impact resistance which imposes excessive wear on tooling, as well as managing complex curved surfaces at tight tolerances.

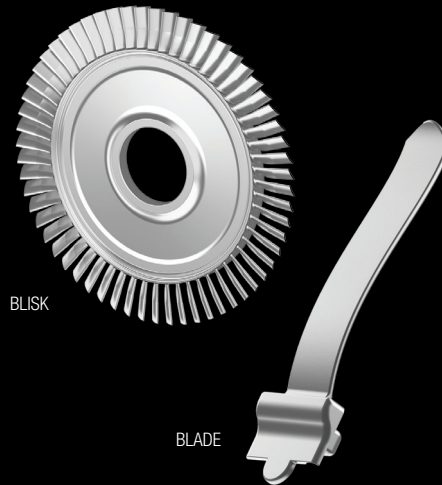

COMPONENTS



### HARVI™ III Solid End Mills

Featuring KCSM15A grade as best in class for titanium machining

Diameter range: 4mm – 25mm (1/8" – 1-1/2")

Available in square, radius, ball nose and taper ball nose

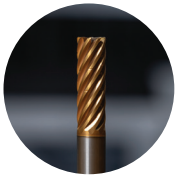

### HARVI IV Solid End Mills

Dynamic milling and finishing operations

Featuring internal coolant supply and chipbreakers for more efficient chip evacuation

8-flute design enhances flexibility and process stability

Diameter range: 10mm – 25mm (3/8" – 1")

Available in square and radius



### Ceramic End Mills

The most efficient solution for roughing nickel-based high-temp alloys

Up to 5X higher productivity than solid carbide end mills



### G0drill Solid Carbide Drills

Marginless design for reduced friction and heat — thus longer tool life

Uninterrupted straight cutting lip allows no starting point for wear and enables even distribution of cutting forces for longer tool life in all materials and less chipping on cutting edge

SOLUTIONS

# STRUCTURE

## BRACKETS, DOOR FRAME & MOUNTS

### BRACKETS

Brackets require deep slot machining in a low thermal conductivity material and the elimination of vibrations to reach required tolerance and surface finish efficiently.

### DOOR FRAME

Creating a perfect shape for door frames can be challenging while machining on titanium's low thermal conductivity and high tension strength.

### MOUNTS

The ratio between depth, thickness of the wall and overall shape require the right application and tools in sequence to reach required surface quality while avoiding vibrations.



COMPONENTS



### SGL Solid Carbide Drills

With through coolant for stainless steels and high-temp alloys

Combines all new SGL point geometry with a patented gashing, a unique flute design and a best-in-class coating

Applicable in KCMS15 grade for stainless steels and high-temp resistant materials

Highly polished surface ensures superior chip evacuation even when low-pressure coolant is applied



### KSEM™ Modular Drills

Covers drilling applications in a diameter range of 12,5 – 40mm (.4921 – 1.5748") up to 10xD

With four large contact surfaces, the insert pocket seat provides maximum stability, even in challenging conditions

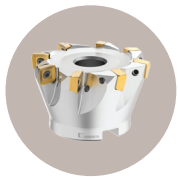

### 7792 High-Feed Milling Cutters

Cover multiple applications like facing, pocketing, ramping, helical interpolation and plunging

Ideal when high MRR and reduced cycle times are a requirement



### HARVI Ultra 8X Helical Milling Cutters

Up to 8 cutting edges per insert

Designed to deliver the highest MRR, especially in high-temp alloys

Lead inserts in various corner radii available

Achieving maximum tool stiffness and tool life

Ideal for machines designed to produce airframe structural parts

**GoDrill Solid Carbide Drills** (see pg. 5)

**HARVI III Solid End Mills** (see pg. 5)

**HARVI IV Solid End Mills** (see pg. 5)

SOLUTIONS

# STRUCTURE RIBS & PANELS

## RIBS & PANELS

This machining requires significant material removal from the original workpiece and highly efficient and productive processes for face and pocket milling when working with delicate, thin-walled structures.

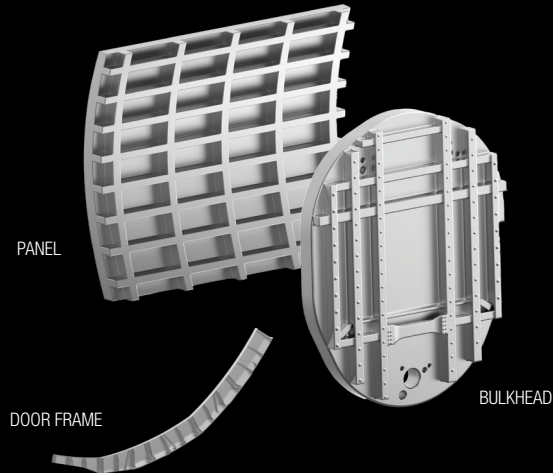

COMPONENTS SOLUTIONS



### G0drill Solid Carbide Drills

Marginless design for reduced friction and heat delivers longer tool life

Uninterrupted straight cutting lip allows no starting point for wear and enables even distribution of cutting forces for longer tool life in all materials and less chipping on cutting edge



### HARVI III Solid End Mills

Featuring KCSM15A grade as best in class for titanium machining

Diameter range: 4mm – 25mm (1/8" – 1-1/2")

Available in square, radius, ball nose and taper ball nose

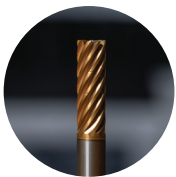

### HARVI IV Solid End Mills

Dynamic milling and finishing operations

Featuring internal coolant supply and chipbreakers for more efficient chip evacuation

8-flute design enhances flexibility and process stability

Diameter range: 10mm – 25mm (3/8" – 1")

Available in square and radius

**SGL Solid Carbide Drills** (see pg. 6)

**7792 High-Feed Milling Cutters** (see pg. 6)

# STRUCTURE BEAMS & SEAT TRACK

## BEAMS

To avoid part deformation, a strategic machining sequence is mandatory to balance productivity and stress on the part.

## SEAT TRACK

Creating a perfect shape for seat tracks can be challenging while machining on titanium's low thermal conductivity and high tension strength.



COMPONENTS



### HARVI III Solid End Mills

Featuring KCSM15A grade as best in class for titanium machining

Diameter range: 4mm – 25mm (1/8" – 1-1/2")

Available in square, radius, ball nose and taper ball nose

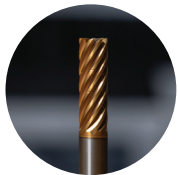

### HARVI IV Solid End Mills

Dynamic milling and finishing operations

Featuring internal coolant supply and chipbreakers for more efficient chip evacuation

8-flute design enhances flexibility and process stability

Diameter range: 10mm – 25mm (3/8" – 1")

Available in square and radius



### HARVI Ultra 8X Helical Milling Cutters

Up to 8 cutting edges per insert

Designed to deliver the highest MRR, especially in high-temp alloys

Lead inserts in various corner radii available

Achieving maximum tool stiffness and tool life

Ideal for machines designed to produce airframe structural parts

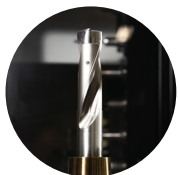

### KSEM Modular Drills

Covers drilling applications in a diameter range of 12,5 – 40mm (.4921 – 1.5748") up to 10xD

With four large contact surfaces, the insert pocket seat provides maximum stability, even in challenging conditions

**SGL Solid Carbide Drills** (see pg. 6)

**GoDrill Solid Carbide Drills** (see pg. 5)

**7792 High-Feed Milling Cutters** (see pg. 6)

SOLUTIONS

# LANDING GEAR BEAMS & AXLES

## BEAMS & AXLES

These components often require custom tooling solutions or heavy machining solutions for sturdy forged titanium materials.

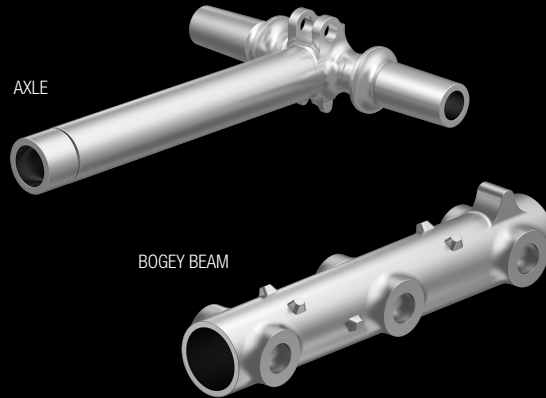

COMPONENTS SOLUTIONS



### KSEM PLUS™ Modular Drill for Large Diameter Drilling

Combines the advantages of a modular drill and an indexable drill  
Provides high speed and feed capability with large length-to-diameter ratio



### FBX™ Drill

4 large chip flutes and 4 cutting edges on outer diameter for fast stock removal on large metal plates or forgings when used in plunging operations  
Center insert with 2 cutting edges and chip splitters for perfect chip formation and maximum feed rates  
Flat bottom drill point design eliminates radial forces, ideal for applications on machines with lower horsepower  
Ideal for pre-machining high-temp alloys and stainless steels

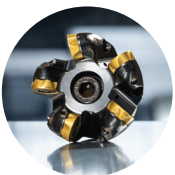

### KSRM™ Daisy Copy Milling Cutters

Engineered for titanium and stainless steels machining  
Anti-rotation components feature 8 indexable positions  
Pocketing, ramping, plunging and helical interpolation capabilities

**HARVI III Solid End Mills** (see pg. 5)

**HARVI IV Solid End Mills** (see pg. 5)

# LANDING GEAR

## LINKS, FITTINGS & BRACKET

### TORSION LINK

These components require deep slotting and pocketing typically on 300M material.

### SPAR FITTING

Machining composite components and aluminum, which consist of thin walls, requires careful part movement and precise and rigid fixturing, while managing machining around multiple pockets.

### BRACKET

This machining process demands precise hole placement on the bracket while adhering to tight tolerances.

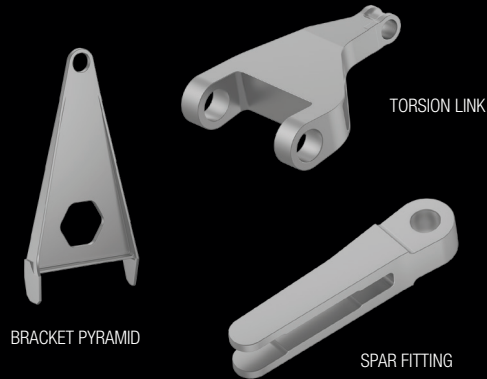

COMPONENTS



### Mill 4-11™ & Mill 4-15™ Shoulder Milling Cutters

Unique design enables multiple passes

Mill 4-11 for roughing to finishing applications in steel, cast iron, stainless steels, non-ferrous materials and high-temp alloys

Mill 4-15 for roughing to finishing applications in steel, cast iron, stainless steels and titanium



### KenTIP™ FS Modular Drills

Covers 6 – 26mm (0.237" – 1.02") diameter range and up to 12xD drilling depths

Large, ultra-high polished chip flutes for hassle-free chip evacuation, enhanced tool life and performance

Large bearing surface positioned for transmission of highest torsional loads without pocket deformation

Coolant delivery to drill point and rake for optimal coolant distribution



### Kenna Universal™ Drills

4-margin land design provides hole straightness and roundness, even when drilling cross holes

Low thrust drill point design has excellent centering capabilities for less stable machining conditions

All shanks fulfill the DIN 6535 and 69090-03 requirements for minimum quantity lubrication

### HARVI Ultra 8X Helical Milling Cutters (see pg. 6)

### HARVI III Solid End Mills (see pg. 5)

### HARVI IV Solid End Mills (see pg. 5)

### 7792 High-Feed Milling Cutters (see pg. 6)

SOLUTIONS

# COMPOSITES

# SPOILERS, FUSELAGE & WING SPARS

## SPOILERS

Spoilers require solutions that can machine varying Carbon Fiber Reinforced Plastics (CFRP) components to achieve reduced delamination, splintering and fraying during trimming and fastener drilling operations.

## FUSELAGE / WING SPAR

Drilling stacked parts is required for assembly, making heat control for carbon compounds, excellent chip evacuation, burr height management and suppression of delamination necessary.

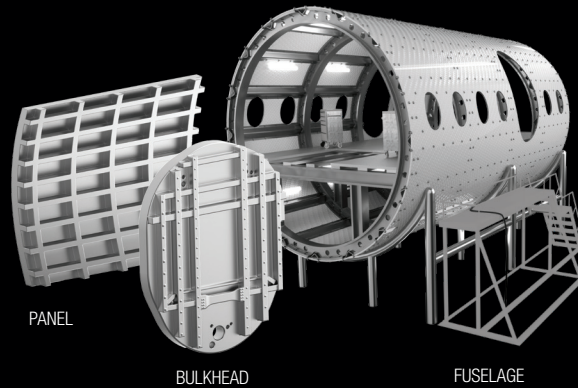

COMPONENTS

HOLEMAKING



### KenTIP FS – SPF

Through coolant with double angle geometry of 128° and 90° to avoid delamination in CFRP applications

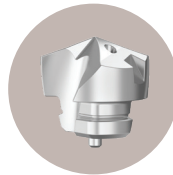

### KenTIP FS – DAL

DAL point geometry for CFRP stacks with metal exit (CFRP-Al and CFRP-Ti), high-temp alloys and non-ferrous metals

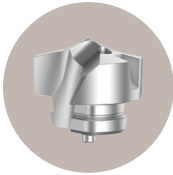

### KenTIP FS – DAV

For vibration assisted drilling of CFRP stacks with metal exit, non-ferrous materials and titanium

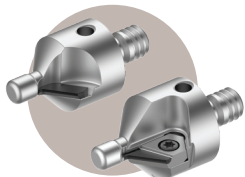

### KenShape™ MaPACS & MaxPACS

For manual countersinking applications on aerospace CFRP components  
MaPACS (brazed) version — Designed for up to three regrinds for lowest cost per part  
MaxPACS (indexable) version — Delivering a highly economical solution without regrinding



### HiPACS

The HiPACS drilling and countersinking tool is a unique high-precision system, achieving 1° angular countersink tolerances in aerospace fastener hole applications

TRIMMING



### KenCut™ Routers

Proprietary substrate optimizes coating adhesion and improves tool life  
Designed to provide high feed rates and promote stable cutting conditions  
Burr-routers designed for trimming and slotting fiberglasses and composites  
Down-cut routers for surface work and floor finishing, with excellent ramping capabilities that eliminate surface delamination

SOLUTIONS

**READY FOR TAKEOFF?**



# Impacting an Industry

We're trusted by some of the best in the industry for aerospace tooling excellence. Lockheed Martin features Kennametal's HARVI solid carbide end mills lineup as a preferred product in the company's internal machining guide. **This resource** is produced by Lockheed Martin Aeronautics' Operations Technology group for internal operations and engineering, as well as global supply-chain partners, and **identifies the most effective parameters and processes for machining material-specific aerospace components.**



## AEROSPACE TOOLING EXCELLENCE

HARVI III is featured as a preferred product in Lockheed Martin's internal machining guides.

# Reaching New Heights

*"Kennametal is helping us solve unique challenges to meet demand more efficiently. They have been a valuable supplier to P&W as we deliver on our company's long-term strategy through their collaboration and expertise in the aerospace machining, tooling and application space."*

**Director, Cold Section Operational Excellence (OpX), Pratt & Whitney**

When a tier Asian aerospace supplier reached out to Kennametal seeking reduced costs for a countersinking operation, our expert team developed an innovative indexable PCD countersink that increased tool life **2X over the competitor tool.**

*"For many years Kennametal has been a valued and trusted partner, providing HDI with technical and business support that is critical to our manufacturing operations. They work directly with us to develop innovative solutions to complex challenges, and the team is highly responsive to our needs."*

**Plant Manager, Héroux Devtek**

# Your Digital Space for Integrated Machining— kennametal.com

One convenient platform for everything you need to build solutions in a collaborative environment.

- Keyword Search
- Browse Products
- Create Solutions and Projects
- Virtual Toolbox
- Solution Finder
- Team Collaboration
- Download Digital Assets
- Shopping

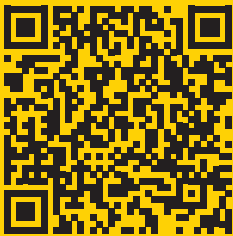

**TRANSFORM  
YOUR WORKFLOW**

**Create.  
Collaborate.  
Innovate.**



# We've Been Cutting Metal Since 1938.



## Our Story Is One of Continuous Innovation

It starts in 1938 with our founder, metallurgist Philip M. McKenna, who after years of research created revolutionary tungsten-titanium carbide alloy cutting tools specifically for working with steel. That single development not only led to a new class of machining tools that cut faster, lasted longer and drove productivity in everything from the automobile to the airplane, but also led to the opening of McKenna Metals Company in Latrobe, Pennsylvania, United States. Today, that company is Kennametal Inc.—a recognized leader in metalworking serving customers across continents and industries including transportation, construction, aerospace and defense, machining and cutting, energy and general engineering. We have a reputation for building innovative solutions for our customers' most challenging applications. The name Kennametal is synonymous for high-quality, high-performance tools that can withstand the most strenuous conditions and bring ease to a wide range of machining operations. We help our customers' operations run longer, faster and with greater precision. We don't cut corners. We cut metal. Your toughest materials don't stand a chance.

# LET'S PUT YOUR MACHINING ON AUTOPILOT



In stock and ready to ship. Order today.  
877.363.6455 | [duramill.ca](http://duramill.ca)

Available  
Today At

**DURAMILL**  
INDUSTRIAL SUPPLIES  
an MSC Company

 **KENNAMETAL**® DISTRIBUTOR

©2025 Kennametal Inc. | All rights reserved. | 295350-25

LET'S TAKE YOUR MANUFACTURING  
TO NEW HEIGHTS

[kennametal.com/aerospace](http://kennametal.com/aerospace)