

# DURAMILL

## INDUSTRIAL SUPPLIES INC.

21 Bradwick Drive, Suites 2-3, Concord, ON L4K 1K6  
 Tel: (905) 738-8665 Fax: (905) 738-4862  
 www.duramill.ca ■ sales@duramill.ca



284 Pinebush Road, Unit 1, Cambridge, ON N1T 1Z6  
 Tel: 519-622-3065 1-800-265-3541 Fax: 519-622-3270  
 www.omnitool.ca ■ sales@omnitool.ca

### TAKE THE EDGE OFF WITH BICONICAL CUTTERS



magafor®

## Chamfering Biconical Cutters

### Miniature and Standard Sizes!

MADE IN FRANCE



BI-FACE

**Bi-Face:** For superior finish operations, Bi-Face has a constant relieved profile. Longitudinal or interpolated work for front and back chamfering of edges and holes.



Hard'X Up to 67HRC

**Hard'X:** AlTiN carbide tool coating with a high hardness of 3500 HV. This coating shows high thermic stability and excellent protection against heat and wear. Ideal for dry machining - high speed cut - in treated steels and dies up to 67 HRC.

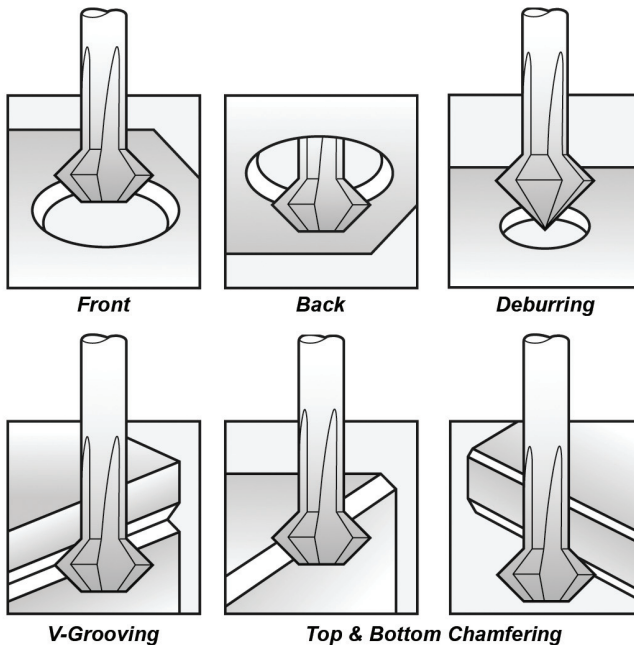

D	Tolerance	L	Angle
0.04 - 0.197	0 - 0.002	± 0.04	±1°
0.236 - 0.63	0 - 0.004	± 0.04	±1°

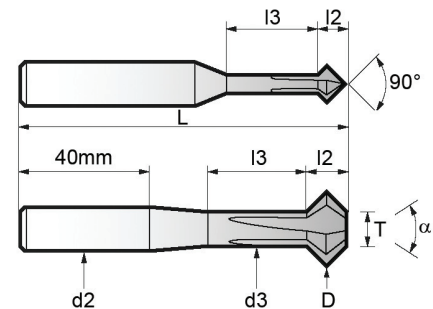

- K15 Carbide
- Special design equals positive cut plus relieving profile
- Unequalled surface finish
- Impressive performance
- Extended tools profile life

**MINIATURE**

#### Miniature 3-Flute Bi-Face 90° Angle - Series 8480

Diameter (Inch)	Diameter (mm)	d2 (Inch)	d3 Max. (Inch)	T Max. (Inch)	L Min. (Inch)	I2 (Inch)	I3 (Inch)	Code	Price
0.04	1	0.118	0.028	0.012	2-3/8	0.02	0.197	314174	\$ 44.60
0.059	1.5	0.118	0.043	0.018	2-3/8	0.029	0.236	314177	43.10
0.079	2	0.118	0.059	0.024	2-3/8	0.037	0.315	314180	41.60
0.118	3	0.118	0.087	0.035	2-3/8	0.059	0.394	314183	41.20

#### Miniature 3-Flute Hard-X 90° Angle - Series 8480-H

Diameter (Inch)	Diameter (mm)	d2 (Inch)	d3 Max. (Inch)	T Max. (Inch)	L Min. (Inch)	I2 (Inch)	I3 (Inch)	Code	Price
0.04	1	0.118	0.028	0.012	2-3/8	0.02	0.197	314186	\$ 46.90
0.059	1.5	0.118	0.043	0.018	2-3/8	0.029	0.236	314189	45.50
0.079	2	0.118	0.059	0.024	2-3/8	0.037	0.315	314192	43.90
0.118	3	0.118	0.087	0.035	2-3/8	0.059	0.394	314195	43.50

Offer valid until March 31st, 2012 or While Quantities Last!

# DURAMILL

## INDUSTRIAL SUPPLIES INC.

21 Bradwick Drive, Suites 2-3, Concord, ON L4K 1K6  
Tel: (905) 738-8665 Fax: (905) 738-4862  
www.duramill.ca ■ sales@duramill.ca



284 Pinebush Road, Unit 1, Cambridge, ON N1T 1Z6  
Tel: 519-622-3065 1-800-265-3541 Fax: 519-622-3270  
www.omnitool.ca ■ sales@omnitool.ca



## TAKE THE EDGE OFF WITH BICONICAL CUTTERS



magafor®

MADE IN FRANCE

### Chamfering Biconical Cutters

### Miniature and Standard Sizes!



#### Standard 4-Flute Bi-Face 90° Angle - Series 8490

Diameter (Inch)	Diameter (mm)	d2 (Inch)	d3 Max. (Inch)	T Max. (Inch)	L Min. (Inch)	I2 (Inch)	I3 (Inch)	Code	Price
0.118	3	0.236	0.087	0.047	4	0.051	0.394	314198	\$ 50.60
0.157	4	0.236	0.114	0.063	4	0.069	0.472	314201	52.50
0.197	5	0.236	0.134	0.079	4	0.091	0.591	314204	55.30
0.236	6	0.236	0.154	0.094	4	0.114	0.709	314207	58.10
0.315	8	0.236	0.193	0.193	4	0.118	1.339	314210	75.90
0.394	10	0.236	0.232	0.232	4	0.157	1.339	314213	92.70
0.472	12	0.236	0.232	0.232	4	0.236	1.339	314216	111.50
0.63	16	0.394	0.311	0.311	4	0.315	1.339	314219	149.00

#### Standard 4-Flute Hard-X 90° Angle - Series 8490-H

Diameter (Inch)	Diameter (mm)	d2 (Inch)	d3 Max. (Inch)	T Max. (Inch)	L Min. (Inch)	I2 (Inch)	I3 (Inch)	Code	Price
0.118	3	0.236	0.087	0.047	4	0.051	0.394	314222	\$ 54.40
0.157	4	0.236	0.114	0.063	4	0.069	0.472	314225	56.30
0.197	5	0.236	0.134	0.079	4	0.091	0.591	314228	59.10
0.236	6	0.236	0.154	0.094	4	0.114	0.709	314231	61.90
0.315	8	0.236	0.193	0.193	4	0.118	1.339	314234	80.60
0.394	10	0.236	0.232	0.232	4	0.157	1.339	314237	98.40
0.472	12	0.236	0.232	0.232	4	0.236	1.339	314240	118.00
0.63	16	0.394	0.311	0.311	4	0.315	1.339	314243	157.30

#### Standard 4-Flute Bi-Face 60° Angle - Series 8460

Diameter (Inch)	Diameter (mm)	d2 (Inch)	d3 Max. (Inch)	T Max. (Inch)	L Min. (Inch)	I2 (Inch)	I3 (Inch)	Code	Price
0.197	5	0.236	0.134	0.134	4	0.11	1.339	314246	\$ 70.30
0.315	8	0.236	0.193	0.232	4	0.213	1.339	314249	92.70
0.472	12	0.394	0.232	0.232	4	0.417	1.339	314252	135.80

#### Standard 4-Flute Hard-X 60° Angle - Series 8460-H

Diameter (Inch)	Diameter (mm)	d2 (Inch)	d3 Max. (Inch)	T Max. (Inch)	L Min. (Inch)	I2 (Inch)	I3 (Inch)	Code	Price
0.197	5	0.236	0.134	0.134	4	0.11	1.339	314255	\$ 74.00
0.315	8	0.236	0.193	0.232	4	0.213	1.339	314258	97.40
0.472	12	0.394	0.232	0.232	4	0.417	1.339	314261	142.40

Offer valid until March 31st, 2012 or While Quantities Last!